

Workhorse CUBE Desktop Mounting Guide

ATTACHING BRACKETS

The brackets attach to the top and bottom of the Cube using two screws for each part. Remove the top handle and attach the brackets as shown. The top bracket attaches to the same threaded screw holes as the top handle.

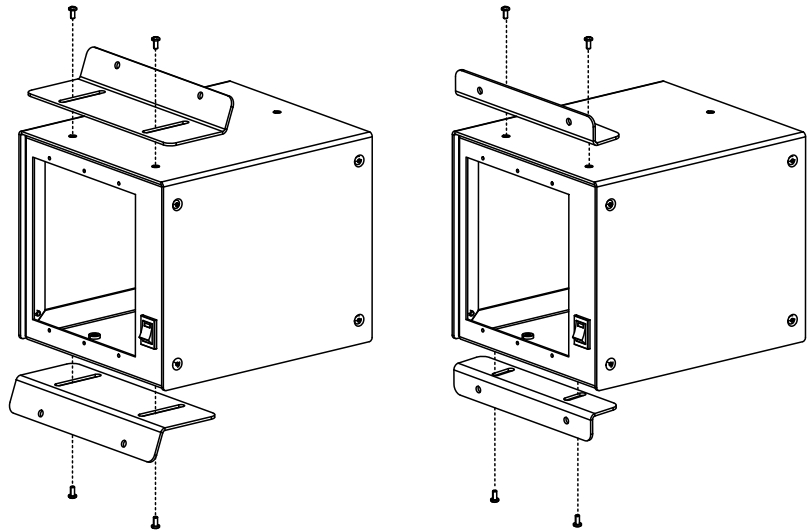

CUTTING OUT THE DESK - TOP

Once the brackets are fastened to the Cube you will need to cut out a hole in your desktop. Use the dimensional data below to mark an opening sized for the Cube. The following steps are a general guide for cutting a hole in your desk. If you are not comfortable with handling power tools like jig-saws then please do not attempt this without help from a carpenter.

1. Check under the desk and ensure there is enough clearance for the Cube. You will need an extra 4" (10cm) of space behind the connector panel to accommodate the cables. The Cube is 7.5" (19cm) deep, so a total of 12" (30cm) clearance is needed for mounting.
2. Use a 90° carpenter's square to draw out the cut lines on the desktop in pencil.
3. To minimize chipping in the desk surface use a straight edge and Exacto knife to score along the pencil lines. Make several passes over each line with moderate force. Do not try and cut a deep score line with one pass.
4. Drill a "starter-hole" for the jig-saw blade and carefully cut along the score lines. A fine-cut jig-saw blade will further minimize chipping in the desk surface.
5. Drop the CUBE into the cut out hole and fasten the brackets to the desktop with #8 wood screws.

ANGLE MOUNT ADAPTER Part No. R700 0107 03

QTY	CONTENTS:
2	Angled mount brackets
4	3/16 machine screws

FLUSH MOUNT ADAPTER Part No. R700 0107 02

QTY	CONTENTS:
2	Flush mount brackets
4	3/16 machine screws

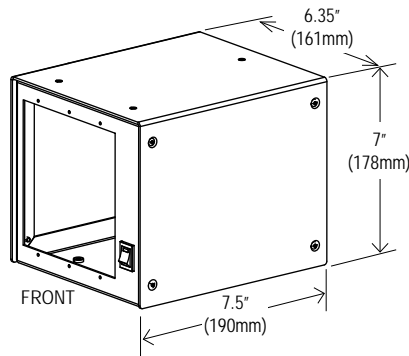

Cube Dimensions

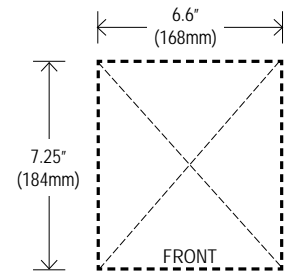

Cut-out Size

Radial Engineering Ltd.
1588 Kebet Way, Port Coquitlam BC V3C 5M5
tel: 604-942-1001 • fax: 604-942-1010
info@radialeng.com • www.radialeng.com

www.radialeng.com

Made in Canada 

THREE YEAR TRANSFERABLE LIMITED WARRANTY

RADIAL ENGINEERING LTD. ("Radial") warrants this product to be free from defects in material and workmanship and will remedy any such defects free of charge according to the terms of this warranty. Radial will repair or replace (at its option) any defective component(s) of this product (excluding finish and wear and tear on components under normal use) for a period of three (3) years from the original date of purchase. In the event that a particular product is no longer available, Radial reserves the right to replace the product with a similar product of equal or greater value. In the unlikely event that a defect is uncovered, please call 604-942-1001 or email service@radialeng.com to obtain an RA number (Return Authorization number) before the 3 year warranty period expires. The product must be returned prepaid in the original shipping container (or equivalent) to Radial or to an authorized Radial repair center and you must assume the risk of loss or damage. A copy of the original invoice showing date of purchase and the dealer name must accompany any request for work to be performed under this limited and transferable warranty. This warranty shall not apply if the product has been damaged due to abuse, misuse, misapplication, accident or as a result of service or modification by any other than an authorized Radial repair center.

THERE ARE NO EXPRESSED WARRANTIES OTHER THAN THOSE ON THE FACE HEREOF AND DESCRIBED ABOVE. NO WARRANTIES WHETHER EXPRESSED OR IMPLIED, INCLUDING BUT NOT LIMITED TO, ANY IMPLIED WARRANTIES OF MERCHANTABILITY OR FITNESS FOR A PARTICULAR PURPOSE SHALL EXTEND BEYOND THE RESPECTIVE WARRANTY PERIOD DESCRIBED ABOVE OF THREE YEARS. RADIAL SHALL NOT BE RESPONSIBLE OR LIABLE FOR ANY SPECIAL, INCIDENTAL OR CONSEQUENTIAL DAMAGES OR LOSS ARISING FROM THE USE OF THIS PRODUCT. THIS WARRANTY GIVES YOU SPECIFIC LEGAL RIGHTS, AND YOU MAY ALSO HAVE OTHER RIGHTS, WHICH MAY VARY DEPENDING ON WHERE YOU LIVE AND WHERE THE PRODUCT WAS PURCHASED.