

JS-2

2-Way Microphone Splitter

Users Guide



Radial Engineering
1845 Kingsway Ave., Port Coquitlam, BC V3C 0H3, Canada
Tel: 604-942-1001 • Fax: 604-942-1010
email: info@radialeng.com

Radial JS2 User Guide - Part #: R870 1055 00 / 02-2024
Copyright 2006 Radial Engineering Ltd. All rights reserved.
Specifications and appearance subject to change without notice.

INPUT PANEL

1. **-30dB PAD** Allows line-level sources to connect to the JS-2's input.
2. **Mic input** For low impedance microphone level signals.
3. **Direct-1 thru** balanced mic-level direct output will pass phantom power to microphone.
4. **Bookend design** 14 gauge steel outer shell creates protective zone around connectors and switches.
5. **Full-bottom no-slip pad** This provides electrical isolation and plenty of "stay-put" friction to keep the JS-2 in one place.

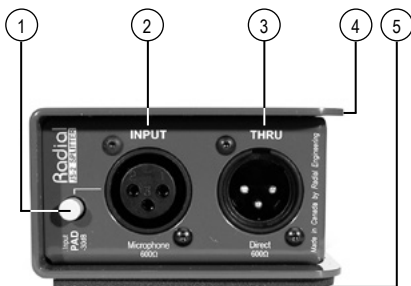

OUTPUT PANEL

6. **Direct-2 thru** Duplicate balanced mic-level direct output.
7. **Ground lift (Direct-2 thru)** Lifts the ground pin-1 on the direct-2 thru XLR connector.
8. **Isolated output** balanced mic-level transformer-isolated.
9. **Ground lift (Isolated output)** Lifts the ground pin-1 on the isolated output XLR connector.

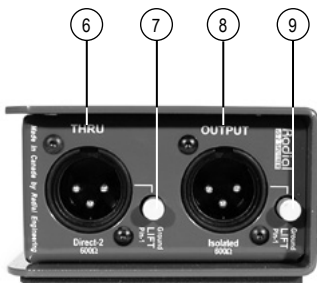

CONSTRUCTION

10. Steel I-beam enclosure eliminates stress that could torque the PC board and cause solder joint failure.
11. Military-grade double-sided PCB with plated through-holes is bolted to welded steel standoffs.
12. Jensen transformer offers outstanding audio performance.
13. Sturdy PC mounted switches are high-cycle rated for long life.

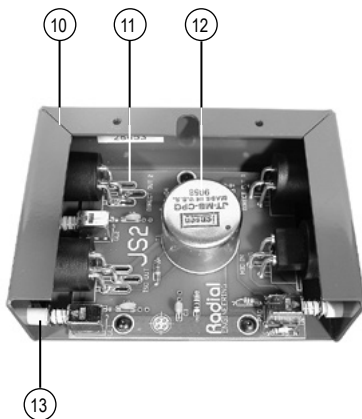

WELCOME

Congratulations on your purchase of the Radial JS•2 mic splitter. This simple yet extremely handy device will likely find its way into all types of applications such as splitting mic signals and distributing signals throughout your sound system. The Radial JS•2 is equipped with the world's finest Jensen bridging transformer to ensure the audio signal is transferred and distributed without distortion and is built using the finest materials to ensure years of trouble-free performance.

We have purposely written this manual to be short, as most users will likely be familiar with the JS•2's applications. We do suggest that you take a moment to read through this document to familiarize yourself with the features that are built in. For more detailed information, please visit the Radial website. This is also where we post questions and answers that come from users after the product is released. If you do not find an answer, we invite you to send us an email at info@radialeng.com and we will do our best to answer your query in a prompt and professional manner.

The Radial JS•2 is a wonderful device that will surely provide you with years of problem-solving connectivity. Enjoy!

INTRODUCTION

Upon inspection, you will notice the Radial JS•2 is equipped with four XLR connectors: the MIC INPUT connector; the DIRECT-1 THRU; the ISOLATED OUTPUT with ground lift switch and the DIRECT-2 THRU with ground lift switch.

Normally, the source microphone connects to the MICROPHONE INPUT and the DIRECT-1 THRU connects to the mixing console that supplies phantom power back to the microphone. If the source is a line-level device, such as a recording interface, the input pad should be engaged to ensure the signal does not saturate the transformer, causing distortion. **Note that the JS•2 will always output a mic-level signal regardless of input level.**

The JS•2's isolated output will then feed a recording device, broadcast truck or other PA system. The advantage of using the transformer-isolated output is that it creates a magnetic bridge between the source and the destination, thus eliminating any direct electrical current from passing. This eliminates problems such as ground loops which can cause buzz and hum in a sound system. A ground lift switch is provided to disconnect the ground path between the input and output to further suppress noise.

The DIRECT-2 THRU output is a direct output and is identical to the DIRECT-1 THRU output, except that it is equipped with a separate ground lift switch. This would be used to send a mic-level signal to an additional destination.

The beauty of the JS•2 is that it is completely passive. This means that it does not require any power whatsoever to make it work. The magic lies in the quality of the transformer we use. Jensen transformers are famous for their exceptional signal handling and low distortion. The JS•2 is equipped with a Jensen JT-MB-CPC mic-bridging transformer that features a laminated nickel core and Faraday shield for optimum signal transfer. You will find the JS•2 to be transparent and very efficient, making it the perfect choice in professional installations.

USING THE JS•2

As with all Radial products, using the JS•2 is simple and straight ahead. Make sure the sound system is turned off and all levels are set to zero before making audio connections. This will avoid any pops in the sound system that could cause damage to speakers.

Connect a microphone or line-level source to the MICROPHONE INPUT on the JS•2. Connect the DIRECT-1 THRU output to the console that supplies phantom power and then the ISOLATED OUTPUT to your monitor console or recording system. If you plan to connect a main and monitor console AND you want to also connect to a recording system, we recommend that the isolated output go to the recorder and the monitor desk connect to the DIRECT-2 THRU output. If you encounter noise, simply depress the ground lift switch.

If you are using the JS•2 with a line-level device such as a recording interface or the output of a mixing console, depress the -30dB input pad. This will reduce the current going into the transformer.

Start by turning up your sound system slowly to test connections before driving at full volume. You are now ready to go!

2-Way Microphone Splitting

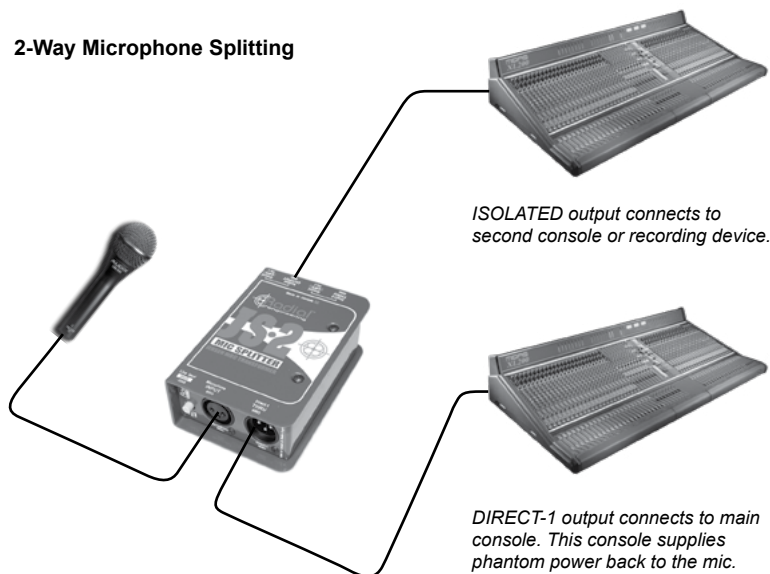

JS-2 BLOCK DIAGRAM

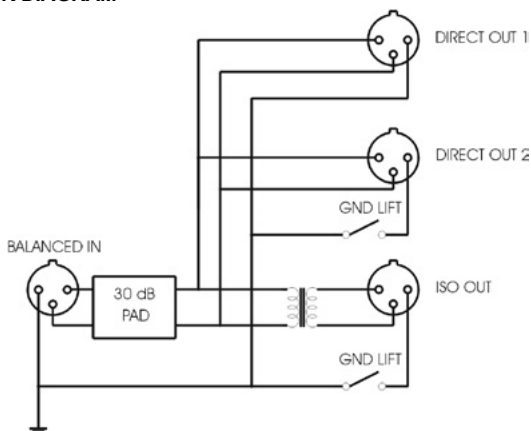

J-RAK

The optional J-RAK is a high density rackshelf for Radial DI's and splitters. It's a 2RU rack chassis that allows up to 8 Radial devices in one neat 19" package. The DI's can be mounted with either the input side or output side facing the front. Ideal for studio or touring. Constructed of 14 gauge steel with a baked enamel finish.



J-CLAMP

The optional J-CLAMP can mount a single Radial device to virtually any surface. Perfect for hiding away inside racks, on podiums or under tables. Constructed of 14 gauge steel with a baked enamel finish.



JS•2 SPECIFICATIONS	
Frequency response	20Hz to 20kHz +0dB/-2dB
Maximum input	+25dBu @1kHz
Phase deviation	+2.8° @ 20Hz
Total harmonic distortion	0.0005% @ 1kHz
Dynamic range	140dB
Input Impedance	Source dependent
Output Impedance	Source dependent
Input pad	-30dB
Power requirement	None, completely passive
Size	3.3" x 5" x 2"
Weight	1.55 lbs.

THREE YEAR TRANSFERABLE LIMITED WARRANTY

RADIAL ENGINEERING LTD. ("Radial") warrants this product to be free from defects in material and workmanship and will remedy any such defects free of charge according to the terms of this warranty. Radial will repair or replace (at its option) any defective component(s) of this product (excluding finish and wear and tear on components under normal use) for a period of three (3) years from the original date of purchase. In the event that a particular product is no longer available, Radial reserves the right to replace the product with a similar product of equal or greater value. In the unlikely event that a defect is uncovered, please call 604-942-1001 or email support@radialeng.com to obtain an RA number (Return Authorization number) before the 3 year warranty period expires. The product must be returned prepaid in the original shipping container (or equivalent) to Radial or to an authorized Radial repair center and you must assume the risk of loss or damage. A copy of the original invoice showing date of purchase and the dealer name must accompany any request for work to be performed under this limited and transferable warranty. This warranty shall not apply if the product has been damaged due to abuse, misuse, misapplication, accident or as a result of service or modification by any other than an authorized Radial repair center.

THERE ARE NO EXPRESSED WARRANTIES OTHER THAN THOSE ON THE FACE HEREOF AND DESCRIBED ABOVE. NO WARRANTIES WHETHER EXPRESSED OR IMPLIED, INCLUDING BUT NOT LIMITED TO, ANY IMPLIED WARRANTIES OF MERCHANTABILITY OR FITNESS FOR A PARTICULAR PURPOSE SHALL EXTEND BEYOND THE RESPECTIVE WARRANTY PERIOD DESCRIBED ABOVE OF THREE YEARS. RADIAL SHALL NOT BE RESPONSIBLE OR LIABLE FOR ANY SPECIAL, INCIDENTAL OR CONSEQUENTIAL DAMAGES OR LOSS ARISING FROM THE USE OF THIS PRODUCT. THIS WARRANTY GIVES YOU SPECIFIC LEGAL RIGHTS, AND YOU MAY ALSO HAVE OTHER RIGHTS, WHICH MAY VARY DEPENDING ON WHERE YOU LIVE AND WHERE THE PRODUCT WAS PURCHASED.

To meet the requirements of California Proposition 65, it is our responsibility to inform you of the following:

WARNING: This product contains chemicals known to the State of California to cause cancer, birth defects or other reproductive harm.

Please take proper care when handling and consult local government regulations before discarding.